

MSKA103X

Built In Steam Oven



60cm Built In Steam Oven

Features and Benefits:

2 Functions with pre-set temperatures	Steam or defrost options for multiple uses, you can use this appliance for more than just cooking. You can use it for cooking, defrosting, sterilizing, yoghurt making, canning and much more
Graphic Touch Controls with Digital Display	Simple to use touch control makes it easy for anyone to cook with the Ariston steam oven. Plus no knobs makes it easier to clean and maintain
Defrost Option	Not only can you cook healthy meals you can also safely defrost foods while minimising the chance of food spoiling
Luce Aesthetics	Designed to match your other Ariston appliances the steam oven fits perfectly with your kitchen
Main Accessories	1 Grid, 1 tray, and 1 perforated tray for your convenience

Technical Specifications:

		Technical	
No. Functions	2	No. Door Glasses	2
Capacity	23L (net)	Lights	1 (top position)
Preselected Temperatures	Y	Cable Length	1.25m
Display	LED	Absorbed Power	1000W
Controls	Touch Panel	Connection	220-240V/50Hz/12A
Finish	Stainless Steel and Black		
Dimensions (W) x (H) x (D)	59.5 x 45.5 x 42.0		

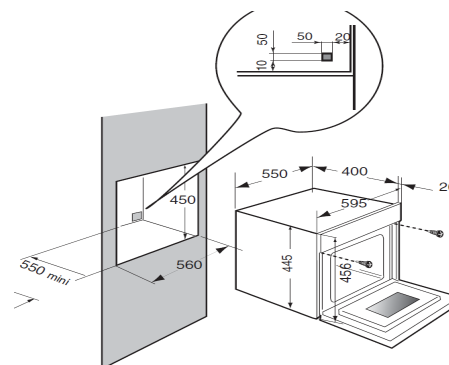

Distributed by Arisit Pty Ltd

40-44 Mark Anthony Drive, Dandenong South VIC 3175 Ph: 1300 762 219 Fax: 03 9768 0838 Website: www.arisit.com
 1A Howe street, Auckland, New Zealand 1145 Ph: (09) 306 1020 Fax: 09 3020077

