

MCKA 103 X

Built In Coffee Machine



60cm Built In Coffee Machine

Features and Benefits:

3 Functions	Coffee, Steam and Hot Water - Allows you to make Espresso coffee, silk smooth steamed milk and tea or hot chocolate all without boiling the kettle.
Graphic Touch Controls with Digital Display	Easy to use with clean lines and aesthetically designed to fit into any kitchen setting.
Coffee Grind Regulator	Built in coffee grind regulator makes this machine versatile to make coffee for any palette.
3 Coffee Types	3 different coffee types available - Short, Normal, or Long.
Fully Automatic Coffee	Just push a button and watch the machine do the rest.

Distributed by Arisit Pty Ltd

40-44 Mark Anthony Drive, Dandenong South VIC 3175 Ph: 1300 762 219 Fax: 03 9768 0838 Website: www.arisit.com

1A Howe Street, Newton, Auckland NZ 1145

Ph:(09) 306 1020 Fax: (09) 302 0077

MCKA 103 X

Built In Coffee Machine

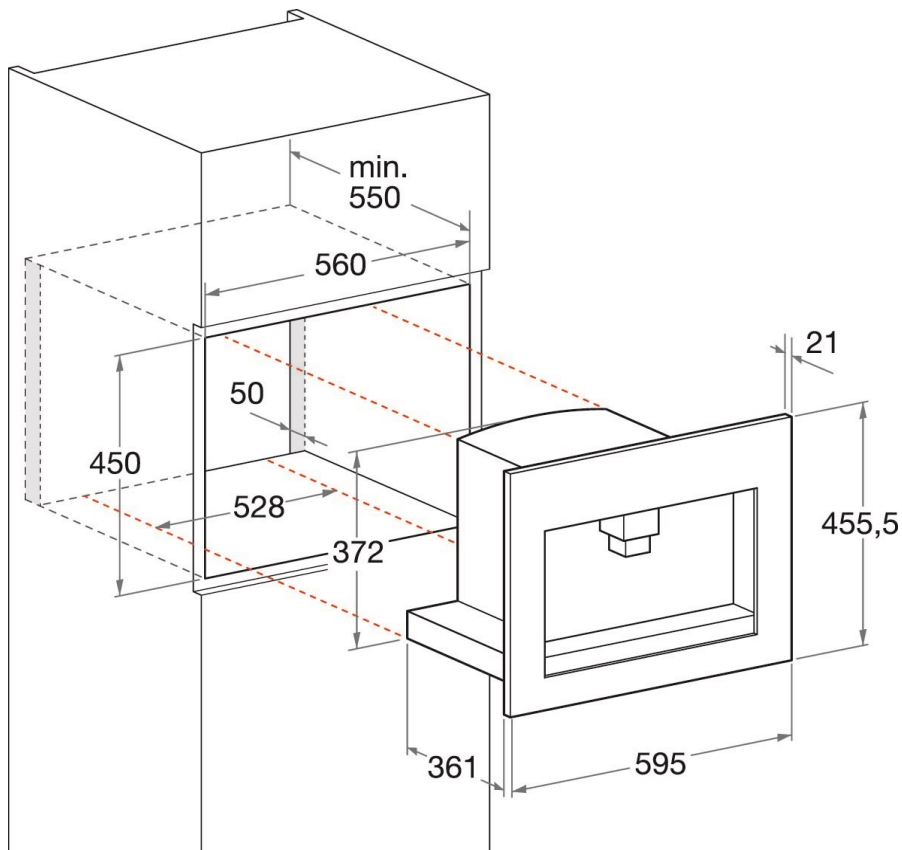

Technical Specifications:

No. Functions	3
Water Reservoir	1.8L
Coffee Reservoir	0.3kg
Water / Beans / Waste Indicator	Y
Finish	Stainless Steel and Black
Dimensions (W) x (H) x (D)	59.5 x 45.5 x 41.3

Technical	
Pump Pressure	15 Bar
Cable Length	2m
Absorbed Power	1350W
Connection	220-240V/50/60Hz/6A

WARNING: technical specifications and product sizes can be varied by the manufacturer, without notice. Cut outs for appliances should only be by physical product measurements. The above information is indicative only.

Distributed by Arisit Pty Ltd

40-44 Mark Anthony Drive, Dandenong South VIC 3175 Ph: 1300 762 219 Fax: 03 9768 0838 Website: www.arisit.com

1A Howe Street, Newton, Auckland NZ 1145

Ph:(09) 306 1020 Fax: (09) 302 0077