

# LTB 6M019 AUS

## Integrated Dishwasher



### Integrated Dishwasher

#### Features and Benefits:

<b>6 Wash Programs:</b>	Daily, Express 40', Half load, Intensive, Normal & Soak
<b>14 Place Settings</b>	More capacity means less wash loads saving water and energy
<b>Overflow Detection device</b>	New Aquastop to ensure you never have a problem with water overflowing
<b>Concealed Heating Element</b>	Less chance of damaging the element or burning plastics if accidentally dropped into the base of the dishwasher.

#### Technical Specifications:

No: of Programs	6
Water Supply	Cold
Place settings	14
Display	LED interface
Concealed Heating Element	Yes
Color	Graphite
Fold down	Yes, lower rack

\*Maximum height of unit is 850mm underbench

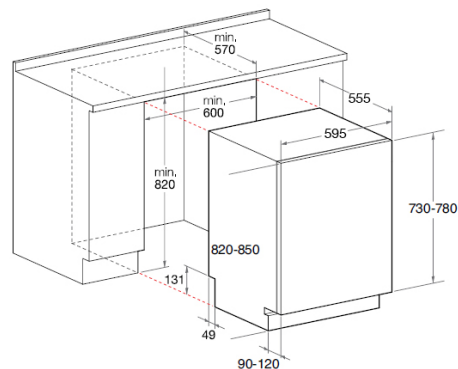

Removable Top	No Top
Noise level	49db
Energy Star	3
Water Star Rating	4.5
Dimensions (W) x (H) x (D)	59.5 x 82 x 55.5

WARNING: technical specifications and product sizes can be varied by the manufacturer, without notice. Cut outs for appliances should only be by physical product measurements. The above information is indicative only.

#### Distributed by Arisit Pty Ltd

40-44 Mark Anthony Drive, Dandenong South VIC 3175

Ph: 1300 762 219

Fax: 03 9768 0838

Website: [www.arisit.com](http://www.arisit.com)

1A Howe Street, Newton, Auckland NZ 1145

Ph:(09) 306 1020

Fax: (09) 302 0077