

LFTM 16 A AUS

Integrated Dishwasher

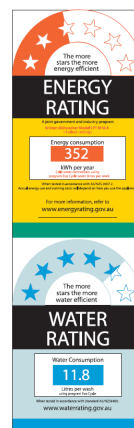

Integrated Dishwasher

Features and Benefits:

6 Wash Programs:	Delicates, Eco, Intensive, Normal, Rapid 35', Soak
14 Place Settings	More capacity means less wash loads saving water and energy
Overflow Detection device	New Aquastop to ensure you never have a problem with water overflowing
Concealed Heating Element	Less chance of damaging the element or burning plastics if accidentally dropped into the base of the dishwasher.

Technical Specifications:

No: of Programs	6		
Water Supply	Hot or Cold		
Place settings	14	Removable Top	No Top
Display	LED interface	Noise level	51db
Concealed Heating Element	Yes	Energy Star	2.5
Color	Graphite	Water Star Rating	4.5
Fold down	Yes, lower rack	Dimensions (W) x (H) x (D)	59.5 x 82 x 57

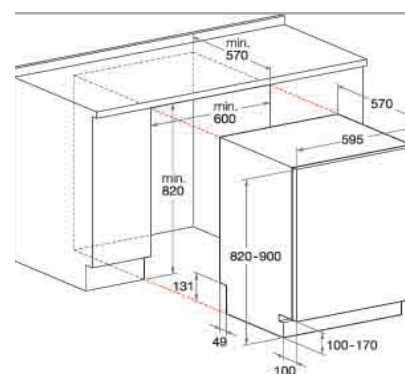

Distributed by Arisit Pty Ltd