

HR 601 C A

60cm Ceramic Cooktop

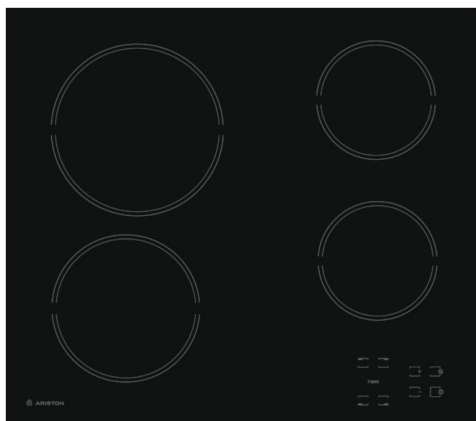

ARISTON



TECHNICAL SPECIFICATIONS

Construction Type/Product Family	Built-In Ceramic
Energy Input/Absorbed Power (Amps)	6200W / 26A
Total Usable Cooking Zones	4
Safety Features	Residual Heat Indicator & Child Lock
Location of Control Panel	Front Touch Controls
Approval Certificates	AUS / NZ
Location & Length of Power Cable	Rear-center / 1.5m
Electrical Connect Requirements (V/Hz)	220-230V/380-400V/50Hz
Surface Material	Black Glass Ceramic
Power Levels	9

FEATURES & BENEFITS



4 Ceramic Cooking Surfaces

Ceramic cooking ensures quick and uniform results, easy to clean and completely safe.



Frameless Design

Not only does it look good, but it is easier to clean without the usual steel lip on the edge of your hob trapping dirt and grime.



Child Safety Touch Control

To avoid programmed Touch Control commands being accidentally changed, or to stop children from activating them. This cooktop is equipped with a safety lock.



Residual Heat Indicators

As long as the element is hot this light will continue to glow. This light will lessen the chance of accidentally burning yourself.



5
YEAR
WARRANTY

ZONES

Front Left Zone Zone Size Power Output	1700 W
Front Right Zone Zone Size Power Output	1200 W
Rear Left Zone Zone Size, Power Output	2100 W
Rear Right Zone Zone Size, Power Output	1200 W

DIMENSIONS

Product Dimensions (W) x (H) x (D)	580 x 52 x 510
Packaging Dimensions (W) x (H) x (D)	670 x 130 x 600
Net Weight/Gross Weight	8kg

DISTRIBUTED BY ARISIT PTY LTD

40-50 Mark Anthony Drive,
Dandenong South VIC 3175
Ph: 1300 762 219
Fax: 03 9768 0838
Website: www.arisit.com

1A Howe Street,
Newton, Auckland NZ 1145
Ph: (09) 306 1020
Website: www.arisit.com



HR 601 C A

60cm Ceramic Cooktop



 **ARISTON**

Product Dimensions

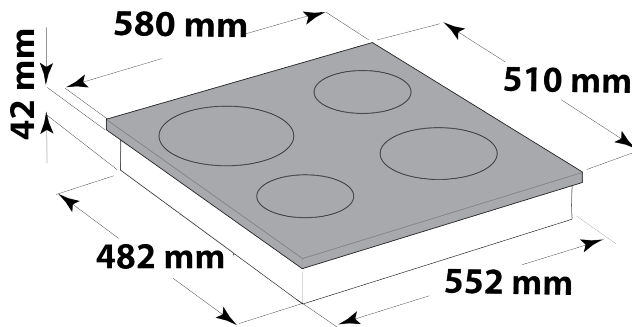

Clearance Requirement & Benchttop Thickness

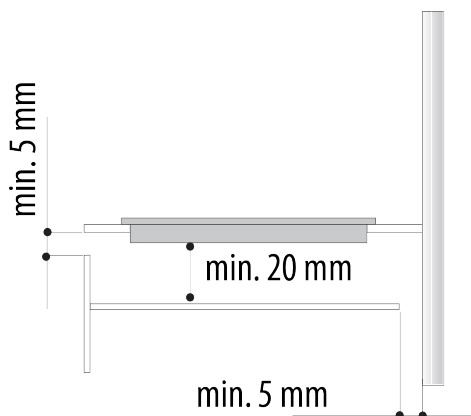

Ventilation Requirements

WARNING: technical specifications and product sizes can be varied by the manufacturer, without notice. Cut outs for appliances should only be by physical product measurements. The above is indicative only.

DISTRIBUTED BY ARISIT PTY LTD

40-50 Mark Anthony Drive,
Dandenong South VIC 3175
Ph: 1300 762 219
Fax: 03 9768 0838
Website: www.arisit.com

1A Howe Street,
Newton, Auckland NZ 1145
Ph: (09) 306 1020
Website: www.arisit.com

