

# HLB 9.8 LTIX

## 90cm Rangehood



### 90cm Rangehood

---

#### Features and Benefits:

3 Speed and 1 Booster

150 MM Ducting

71 dBA

2 LED x 3 watt Lights

Dishwasher safe filters

---

#### **Distributed by Arisit Pty Ltd**

40-44 Mark Anthony Drive, Dandenong South VIC 3175 Ph: 1300 762 219 Fax: 03 9768 0838 Website: [www.arisit.com](http://www.arisit.com)

1A Howe Street, Newton, Auckland NZ 1145

Ph:(09) 306 1020 Fax: (09) 302 0077

# HLB 9.8 LTIX

## 90cm Rangehood

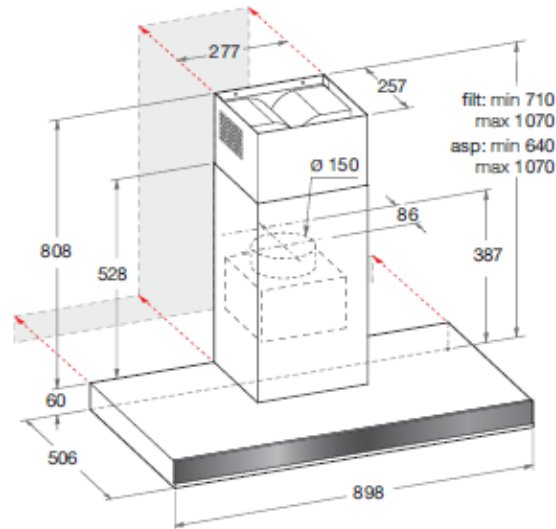

### Technical Specifications:

Extraction Rate	772 m3/h
Speed Settings	3 + booster
Lighting Type / Position	2 LEDx 3 Watt / Front
Control Type	Touch control glass and display
Colour	Stainless Steel
Filter Type	Aluminium filters
Dimensions (W) x (H) x (D)	89.8 x 70 x 50.6

Technical	
Connection	220/240V~ / 50/60Hz
Ducting Outlet	150

WARNING: technical specifications and product sizes can be varied by the manufacturer, without notice. Cut outs for appliances should only be by physical product measurements. The above information is indicative only.

### Distributed by Arisit Pty Ltd

40-44 Mark Anthony Drive, Dandenong South VIC 3175 Ph: 1300 762 219 Fax: 03 9768 0838 Website: www.arisit.com  
 1A Howe Street, Newton, Auckland NZ 1145 Ph:(09) 306 1020 Fax: (09) 302 0077