

HKE 9 X

90cm Canopy



 **ARISTON**



90cm Canopy with Black Glass Fascia

Features and Benefits:

780 m3/h extraction	Removes cooking odours with ease
Black Glass Fascia with Touch Controls	Stylish and easy to use. Touch control for a more modern aesthetic
Halogen Lighting	Giving extra light when needed in the kitchen
3 Speed Settings with booster	Depending on what you're cooking you can vary the amount of extraction as required
Washable Aluminium Filters	Easily maintain your hood as the filters can be removed and washed either by hand or in the dishwasher

Distributed by Arisit Pty Ltd

40-44 Mark Anthony Drive, Dandenong South VIC 3175 Ph: 1300 762 219 Fax: 03 9768 0838 Website: www.arisit.com

1A Howe street, Auckland, New Zealand 1145 Ph: (09) 306 1020 Fax: 09 3020077

HKE 9 X

90cm Canopy

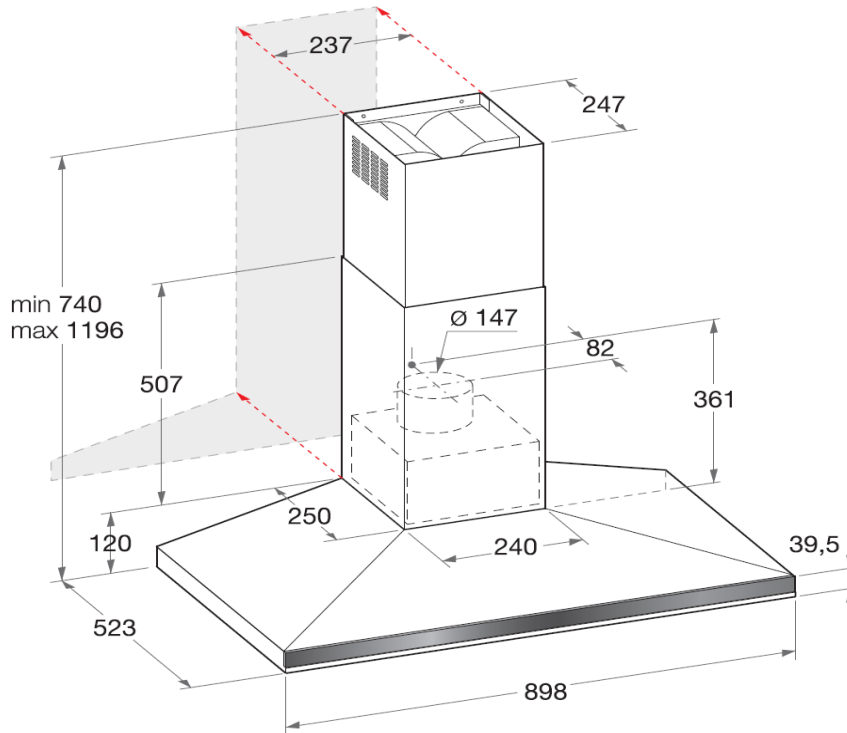

Technical Specifications:

Extraction Rate	780 m3/h
Speed Settings	3
Lighting Type / Position	2 x Halogens / Front
Control Type	Electronic Touch Control
Colour	Stainless Steel with Black Glass Fascia
Filter Type	Aluminum
Dimensions (W) x (H) x (D)	900 x 1196 x 523
dBa Level	63 dBa

Technical	
Connection	220/240V / 50Hz/ 355W
Ducting Outlet	150mm

WARNING: technical specifications and product sizes can be varied by the manufacturer, without notice. Cut outs for appliances should only be by physical product measurements. The above information is indicative only.

Distributed by Arisit Pty Ltd

40-44 Mark Anthony Drive, Dandenong South VIC 3175 Ph: 1300 762 219 Fax: 03 9768 0838 Website: www.arisit.com

1A Howe Street, Newton, Auckland NZ 1145

Ph:(09) 306 1020 Fax: (09) 302 0077