

FI7 891 SP IX A AUS

60Cm Built-In Pyrolytic Oven



TECHNICAL SPECIFICATIONS

Construction Type/Product Family	Built-in oven
Main colour	Stainless steel
Display type	LCD
Control Type	Electronic
Capacity	81 litres
Timer	Electronic
Hinge	Soft-close
Door glasses	4
Oven guides	Telescopic
Grids	2
Enamelled baking trays	1
Deep trays	1
Cleaning system	Pyrolytic
Cooking functions	MF8
Multiflow	Yes
Temperature control	Electronic
Child lock	Yes
Motorised turn spit	Yes
Meat probe	Yes
Voltage	220-240 V
Frequency	50-60 Hz
Current	16A
Absorbed total power	3650 W
Grill power	2450 W

FEATURES & BENEFITS



Multi-flow technology

Designed to give you free reign in your desire to try things out, letting you express your creativity in the kitchen with consistently excellent results.



Pyrolytic clean

A cleaning cycle that need no chemical products, thanks to the temperature of 470° C that reduces the grease to ash. The residue ash can then be easily removed using a damp cloth.



28 preset recipes

Enjoy perfectly cooked dishes with 28 automatic pre-set recipes selected using the intuitive touch controls.

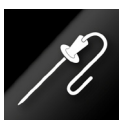

Meat probe

Insert the meat probe prior to cooking and monitor the temperature during the cooking process.



Telescopic guides

Move things in and out of the oven simply and safely with extendable telescopic shelves



Soft-close doors

The soft-closing device is a system that uses next-generation hinges to gently shut the oven door, and prevent it from banging.



5 YEAR WARRANTY on parts and labour.

DIMENSIONS

Product Dimensions (W) x (H) x (D)	595 x 595 x 538
Package Dimensions (W) x (H) x (D)	
Built-In Hole Dimensions (W) x (H) x (D)	560-568 x 574-601 x 550-630
Net Weight/Gross Weight	36/38 kg

www.ariston.com.au

DISTRIBUTED BY ARISIT PTY LTD
40-50 Mark Anthony Drive,
Dandenong South VIC 3175
Ph: 1300 762 219
Fax: 03 9768 0838
Website: www.arisit.com

1A Howe Street,
Newton, Auckland NZ 1145
Ph: (09) 306 1020
Website: www.arisit.com



FI7 891 SP IX A AUS

60Cm Built-In Pyrolytic Oven

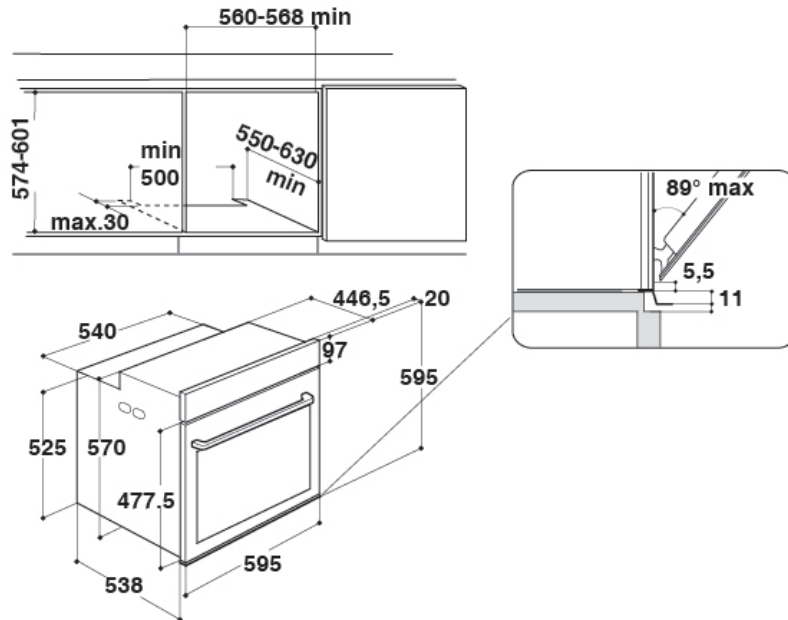

WARNING: Technical specifications and product sizes can be varied by the manufacturer, without notice. Cut outs for appliances should only be by physical product measurements. The above is indicative only.

www.ariston.com.au

DISTRIBUTED BY ARISIT PTY LTD
40-50 Mark Anthony Drive,
Dandenong South VIC 3175
Ph: 1300 762 219
Fax: 03 9768 0838
Website: www.arisit.com

1A Howe Street,
Newton, Auckland NZ 1145
Ph: (09) 306 1020
Website: www.arisit.com

