

FI5 854 P IX A AUS

60cm Built-In Pyrolytic Oven



FEATURES & BENEFITS



Multi-flow technology

Designed to give you free reign in your desire to try things out, letting you express your creativity in the kitchen with consistently excellent results.



Pyrolytic clean

A cleaning cycle that need no chemical products, thanks to the temperature of 470° C that reduces the grease to ash. The residue ash can then be easily removed using a damp cloth.



10 + 6 cooking programs

Functions: Conventional, Grill, Forced air, Convection Bake, Auto Casserole, Auto Meat, Auto Maxi Cooking, Auto Bread, Auto Pizza, Auto Pastry Cakes
Special Functions: Fast Preheat, Turbo Grill, Eco Forced Air, Keep Warm, Rising, Automatic Pyro Cleaning



81 litre capacity

Large capacity for cooking in larger dishes.



5 YEAR WARRANTY on parts and labour.

TECHNICAL SPECIFICATIONS

Construction Type/Product Family	Built-in oven
Main colour	Stainless steel
Display type	LCD
Control Type	Electronic
Capacity	81 litres
Timer	Electronic
Hinge	Standard
Door glasses	4
Oven guides	Grids
Grids	2
Enamelled baking trays	1
Deep trays	1
Cleaning system	Pyrolytic
Cooking functions	10 functions + 6 special
Multiflow	Yes
Temperature control	Electronic
Child lock	Yes
Motorised turn spit	No
Meat probe	No
Voltage	220-240 V
Frequency	50-60 Hz
Current	16A
Absorbed total power	3650 W
Grill power	3650 W

DIMENSIONS

Product Dimensions (W) x (H) x (D)	595 x 595 x 538
Built-In Hole Dimensions (W) x (H) x (D)	560-568 x 574-601 x 550-630
Net Weight/Gross Weight	36/38 kg

www.ariston.com.au

DISTRIBUTED BY ARISIT PTY LTD
 40-50 Mark Anthony Drive,
 Dandenong South VIC 3175
 Ph: 1300 762 219
 Fax: 03 9768 0838
 Website: www.arisit.com

1A Howe Street,
 Newton, Auckland NZ 1145
 Ph: (09) 306 1020
 Website: www.arisit.com



FI5 854 P IX A AUS

60cm Built-In Pyrolytic Oven

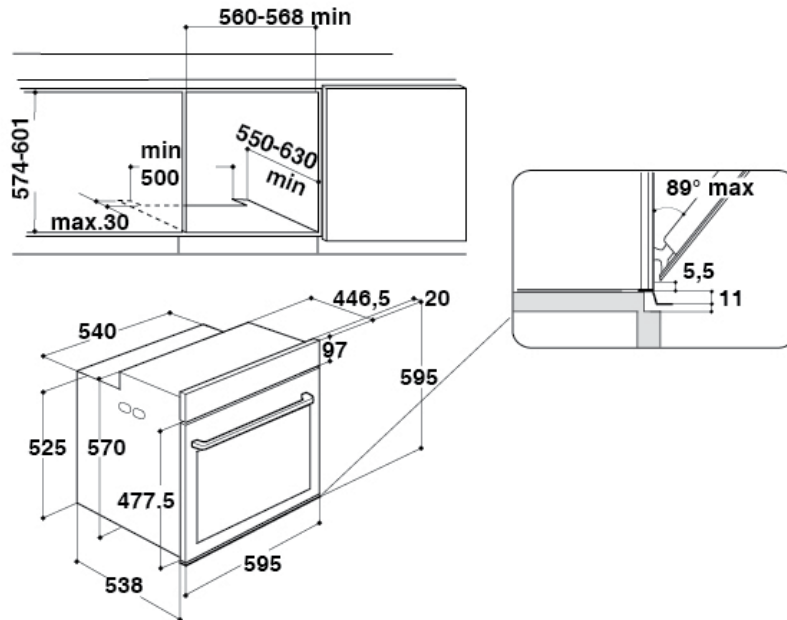

WARNING: Technical specifications and product sizes can be varied by the manufacturer, without notice. Cut outs for appliances should only be by physical product measurements. The above is indicative only.

www.ariston.com.au

DISTRIBUTED BY ARISIT PTY LTD
40-50 Mark Anthony Drive,
Dandenong South VIC 3175
Ph: 1300 762 219
Fax: 03 9768 0838
Website: www.arisit.com

1A Howe Street,
Newton, Auckland NZ 1145
Ph: (09) 306 1020
Website: www.arisit.com

