

FA3S 841 P IX A AUS

60cm Built-In Steam Pyrolytic Oven



TECHNICAL SPECIFICATIONS

Construction Type/Product Family	Built-in oven
Main colour	Stainless steel
Display type	LCD
Control Type	Mechanical
Capacity	77 litres
Timer	Electronic
Door glasses	3
Grids	2
Enamelled baking trays	1
Deep trays	1
Cleaning system	Pyrolytic
Cooking functions	MF8
Multiflow	Yes
Temperature control	Electronic
Child lock	Electronic
Voltage	220-240 V
Frequency	50-60 Hz
Current	16A
Absorbed power	3300 W

FEATURES & BENEFITS



Multi-flow technology

Designed to give you free reign in your desire to try things out, letting you express your creativity in the kitchen with consistently excellent results.



Steam cooking

Maintain the nutritional values and vitamins thanks to the gentle cooking of steam.



Pyrolytic clean

A cleaning cycle that need no chemical products, thanks to the temperature of 470° C that reduces the grease to ash. The residue ash can then be easily removed using a damp cloth.



5 YEAR WARRANTY on parts and labour.

DIMENSIONS

Product Dimensions (W) x (H) x (D)	595 x 595 x 551
Built-In Hole Dimensions (W) x (H) x (D)	560 x 585 x 560
Net Weight/Gross Weight	36/38 kg

www.ariston.com.au

DISTRIBUTED BY ARISIT PTY LTD
40-50 Mark Anthony Drive,
Dandenong South VIC 3175
Ph: 1300 762 219
Fax: 03 9768 0838
Website: www.arisit.com

1A Howe Street,
Newton, Auckland NZ 1145
Ph: (09) 306 1020
Website: www.arisit.com



FA3S 841 P IX A AUS

60cm Built-In Steam Pyrolytic Oven

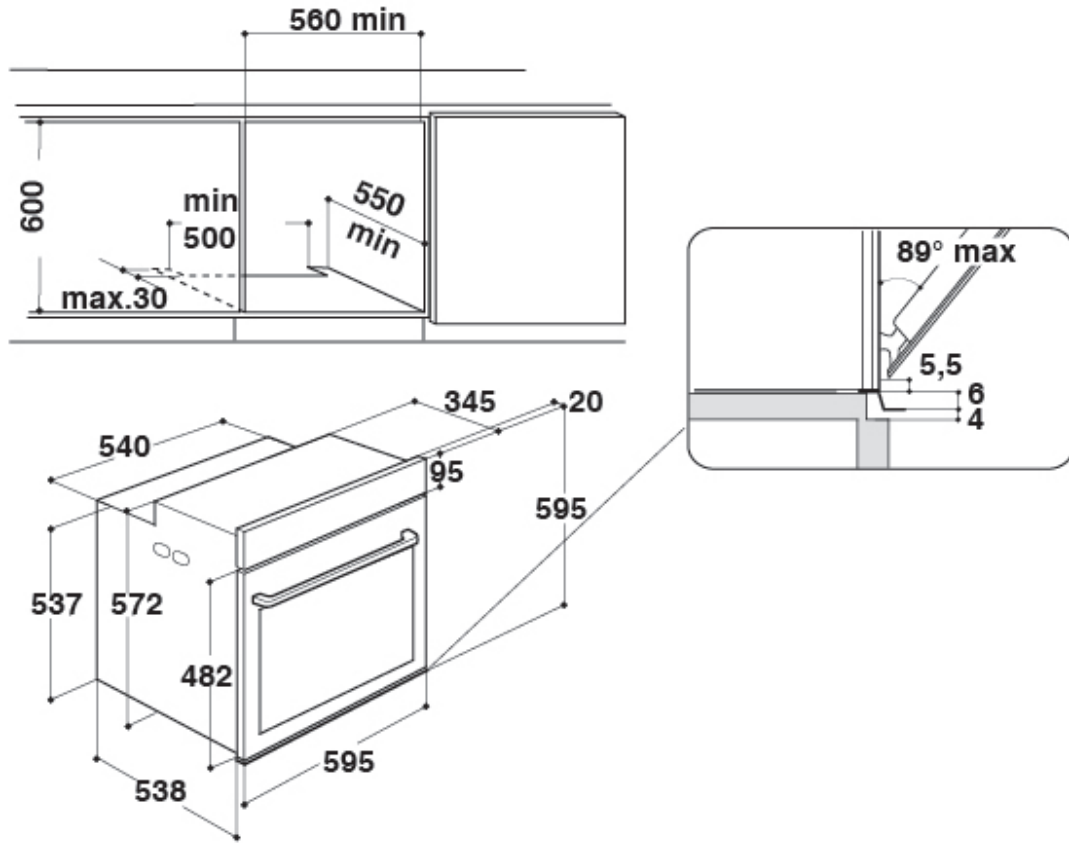

WARNING: Technical specifications and product sizes can be varied by the manufacturer, without notice. Cut outs for appliances should only be by physical product measurements. The above is indicative only.

www.ariston.com.au

DISTRIBUTED BY ARISIT PTY LTD
40-50 Mark Anthony Drive,
Dandenong South VIC 3175
Ph: 1300 762 219
Fax: 03 9768 0838
Website: www.arisit.com

1A Howe Street,
Newton, Auckland NZ 1145
Ph: (09) 306 1020
Website: www.arisit.com

