

FA3 844 H IX A AUS

60cm Built-In Oven



TECHNICAL SPECIFICATIONS

Construction Type/Product Family	Built-in oven
Main colour	Stainless steel
Display type	7 segment
Control Type	Electronic
Capacity	77 litres
Timer	Electronic
Hinge	Standard
Door glasses	2
Oven guides	Grids
Grids	1
Enamelled baking trays	1
Deep trays	0
Cleaning system	Diamond
Cooking functions	MF5
Multiflow	No
Child lock	No
Motorised turn spit	No
Meat probe	No
Voltage	220-240 V
Frequency	50-60 Hz
Current	13A
Absorbed total power	2450 W
Grill power	1800 W

FEATURES & BENEFITS



8 cooking functions

Fast preheat, Pizza / Bread, Conventional, Defrost, Forced air, Grill, Turbo Grill



Diamond clean

The entire oven has a special coating with cleaning properties, that is activated during the steam clean cycle that reaches a temperature of 90° and lasts just 35 minutes.



Tilting grill

The upper grill element is able to tilt down at an angle for easy cleaning of the top cavity.



5 YEAR WARRANTY on parts and labour.

DIMENSIONS

Product Dimensions (W) x (H) x (D)	595 x 595 x 549
Built-In Hole Dimensions (W) x (H) x (D)	560 x 585 x 560
Net Weight/Gross Weight	31/33 kg

www.ariston.com.au

DISTRIBUTED BY ARISIT PTY LTD
40-50 Mark Anthony Drive,
Dandenong South VIC 3175
Ph: 1300 762 219
Fax: 03 9768 0838
Website: www.arisit.com

1A Howe Street,
Newton, Auckland NZ 1145
Ph: (09) 306 1020
Website: www.arisit.com



FA3 844 H IX A AUS

60cm Built-In Oven

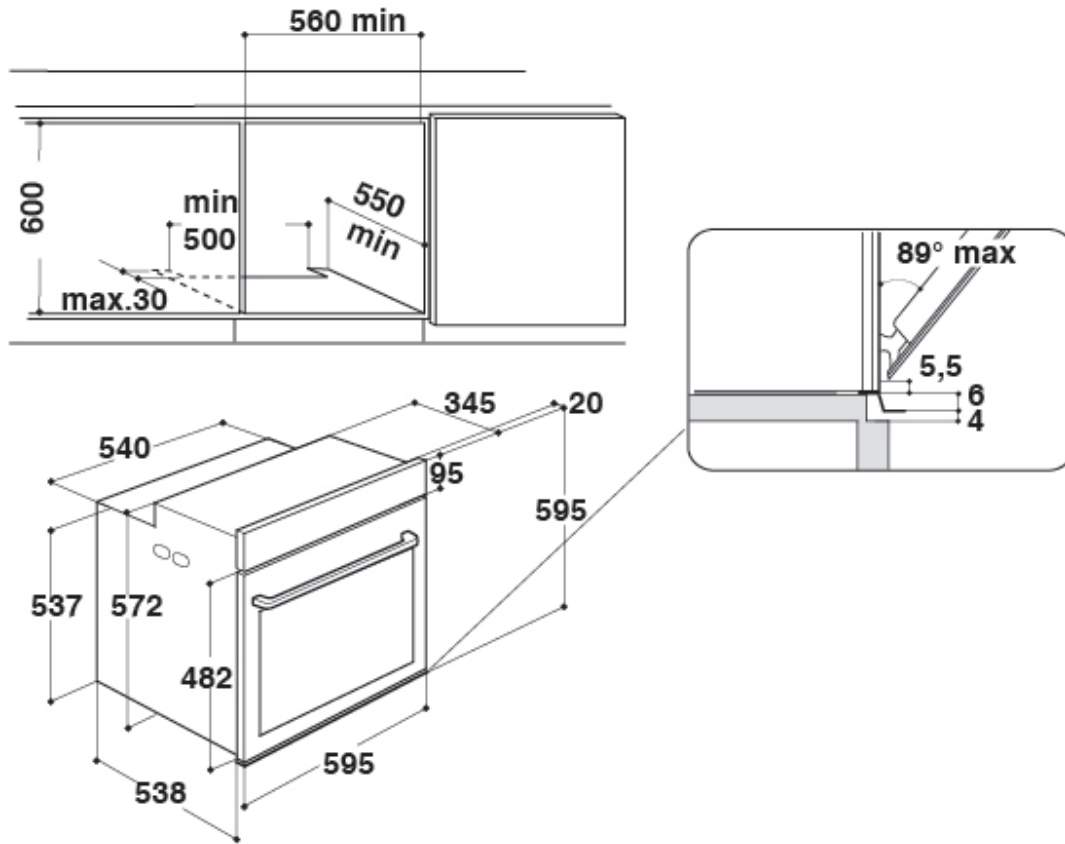

WARNING: Technical specifications and product sizes can be varied by the manufacturer, without notice. Cut outs for appliances should only be by physical product measurements. The above is indicative only.

www.ariston.com.au
DISTRIBUTED BY ARISIT PTY LTD
40-50 Mark Anthony Drive,
Dandenong South VIC 3175
Ph: 1300 762 219
Fax: 03 9768 0838
Website: www.arisit.com

1A Howe Street,
Newton, Auckland NZ 1145
Ph: (09) 306 1020
Website: www.arisit.com

