

FA2 834 H IX A AUS

60cm Built In Oven



 **ARISTON**



60cm Built In Oven

Features and Benefits:

10+2 Function	The large array of programs makes this oven extremely versatile, Multiflow technology, Pizza, Bread, Conventional, Forced air, Grill, Turbo grill and Grill tilting
Diamond Clean	The entire oven has a special coating with cleaning properties, that is activated during the steam clean cycle that reaches a temperature of 90° and lasts just 35 minutes. The stains are softened and can be easily removed using a damp cloth.
Tilting Grill	The upper grill element is able to tilt down at an angle for easy cleaning of the top cavity.
77Lt	Large capacity, perfect for entertaining

Distributed by Arisit Pty Ltd

40-44 Mark Anthony Drive, Dandenong South VIC 3175
1A Howe Street, Newton, Auckland NZ 1145

Ph: 1300 762 219
Ph:(09) 306 1020

Fax: 03 9768 0838
Fax: (09) 302 0077

Website: www.arisit.com

FA2 834 H IX A AUS

60cm Built In Oven



ARISTON

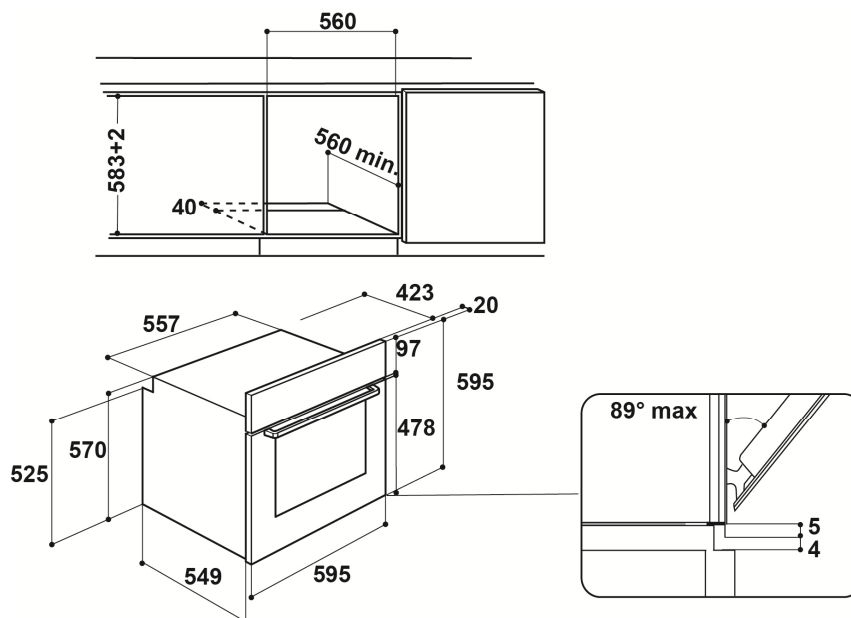

Technical Specifications:

Technical Specifications	
Voltage (V)	220-240
Frequency (Hz)	50-60
Absorbed Current (A)	12
Type of energy	Electric
Absorbed Power (W)	2750
Oven Capacity	77 ltr
Plug and Lead	15 AMP
Height of the product	595
Depth of the product	549
Width of the product	595

WARNING: technical specifications and product sizes can be varied by the manufacturer, without notice. Cut outs for appliances should only be by physical product measurements. The above information is indicative only.

Distributed by Arisit Pty Ltd

40-44 Mark Anthony Drive, Dandenong South VIC 3175 Ph: 1300 762 219 Fax: 03 9768 0838 Website: www.arisit.com

1A Howe Street, Newton, Auckland NZ 1145

Ph:(09) 306 1020 Fax: (09) 302 0077