

CE6VM3X

60cm Freestanding Oven



ARISTON



60cm Freestanding Oven

Features and Benefits:

5 Oven functions	Traditional Oven, Multilevel, Top Oven, Grill & Gratin
4 Ceramic Elements	Easy to use and easy to clean, 1 quick ring 2100W, 1 quick ring 1700W, 2 quick ring 1200W
Storage Drawer	Easy accessible storage drawer to keep your larger pans in
Stainless Steel colour	Look sleeks and suits any kitchen design

Distributed by Arislt Pty Ltd

1A Howe street, Auckland, New Zealand 1145 Ph: (09) 306 1020 Fax: 09 3020077

CE6VM3X

60cm Freestanding Oven

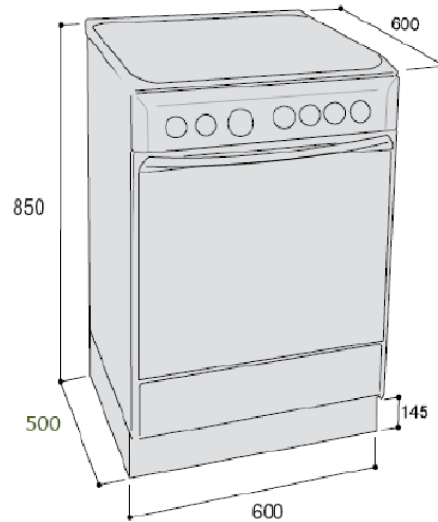

Technical Specifications:

4 Ceramic Elements:

- 1 Quick Ring 2100 W
- 1 Quick Ring 1700 W
- 2 Quick Ring 1200 W

SPECIFICATIONS

230 V ~ 50Hz 8450 watts
850 (H) x 600 (W) x 600(D)

WARNING: technical specifications and product sizes can be varied by the manufacturer, without notice. Cut outs for appliances should only be by physical product measurements. The above information is indicative only.

Website: www.aristonbrand.com

1A Howe Street, Newton, Auckland NZ 1145

Ph:(09) 306 1020 Fax: (09) 302 0077