

ARU52S

52cm Undermount Hood



ARISTON



52cm Undermount Hood

Features and Benefits:

500 m³/h Extraction	Removes cooking odours with ease
55dB Noise Rating	Quiet operation makes this unit perfect for open plan kitchens
Halogen Lighting	Giving extra light when needed in the kitchen
3 Speed Settings	Depending on what you're cooking you can vary the amount of extraction as required

Distributed by Arisit Pty Ltd

40-44 Mark Anthony Drive, Dandenong South VIC 3175 Ph: 1300 762 219 Fax: 03 9768 0838 Website: www.arisit.com
1A Howe street, Auckland, New Zealand 1145 Ph: (09) 306 1020 Fax: 09 3020077

ARU52S

52cm Undermount Hood

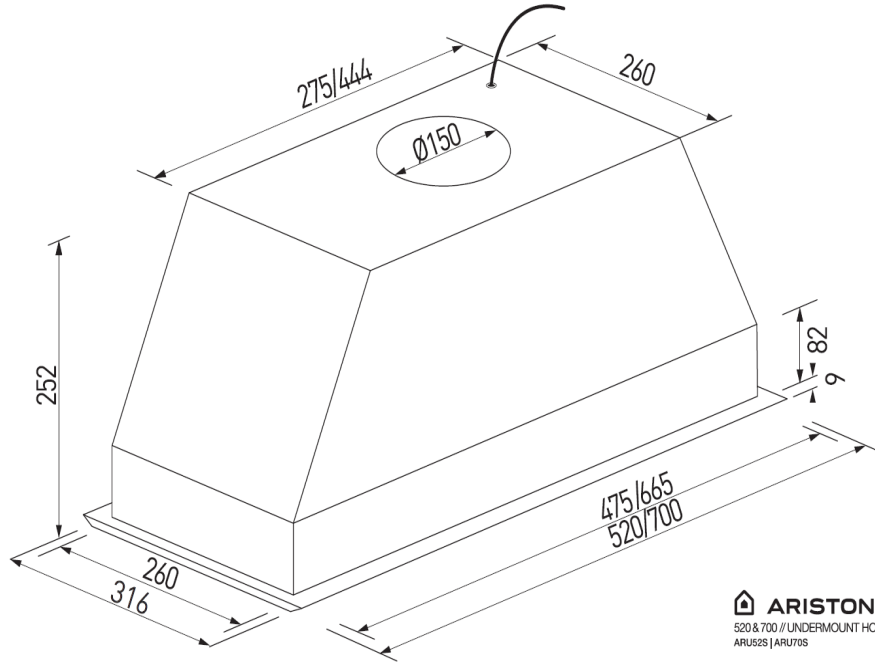

ARISTON
520 & 700 // UNDERMOUNT HOOD
ARU52S | ARU70S

Technical Specifications:

Extraction Rate	500 m ³ /h
Speed Settings	3
Lighting Type / Position	Halogen / Rear
Control Type	Push Button
Colour	White with Stainless Steel Fascia
Filter Type	Aluminum
dB Rating	55
Dimensions (W) x (H) x (D)	520 x 252 x 286

Technical	
Connection	240V~ 50/60Hz 10A
Ducting Outlet	150mm

WARNING: technical specifications and product sizes can be varied by the manufacturer, without notice. Cut outs for appliances should only be by physical product measurements. The above information is indicative only.

Distributed by Arisit Pty Ltd

40-44 Mark Anthony Drive, Dandenong South VIC 3175 Ph: 1300 762 219 Fax: 03 9768 0838 Website: www.arisit.com

1A Howe Street, Newton, Auckland NZ 1145

Ph:(09) 306 1020 Fax: (09) 302 0077